

WitaTrap® Complete Plum Fruit Moth Trap Set

Assembly of the WitaTrap® Delta Super Trap:

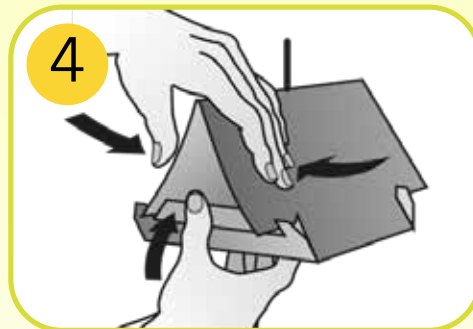
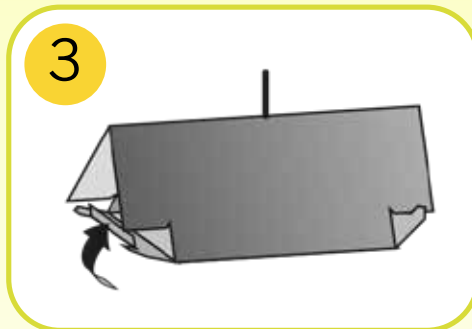
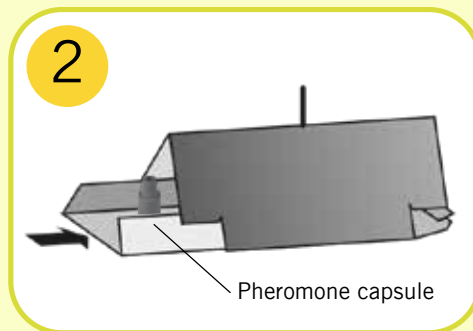
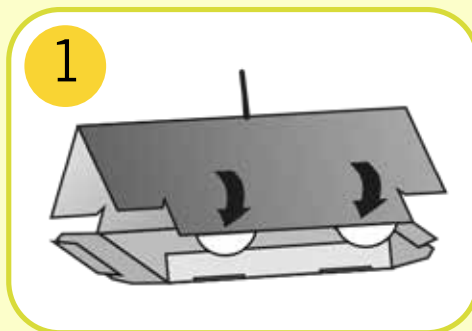

Assembly:

- 1 Fold the trap body together and insert the fastening tabs sideways through the provided slits.
- 2 Remove the adhesive base from the foil and pull off the protective film. Remove the pheromone capsule from the aluminium sachet and place it in the centre of the adhesive base. Now insert the adhesive base with pheromone (attractant) with the glued surface upwards into the body of the trap.
- 3 Fold the lateral flaps of the trap upwards and insert them in the provided slits to ensure that the adhesive base cannot fall out.
- 4
- 5 Attach the suspension wire to the provided hole and hang the completed trap in accordance with instructions. (See inside page)

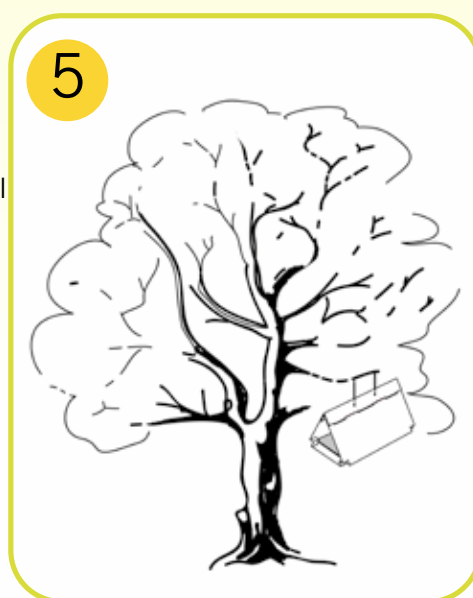

Contents: One trap set

consisting of: 1 trap body (WitaTrap® Delta Super Trap), 2 adhesive bases (separately packaged!), 2 pheromone capsules (separately packaged!), 1 suspension wire for mounting and detailed instructions for use.

Art. No.: 343411



We have other trap sets available! Let us know your needs!

www.witasek.com

witasek Witasek-Allee 2 • 9560 Feldkirchen/Austria • Tel.: +43 (0) 4276 / 3230
Fax: +43 (0) 4276 / 2088-399 • office@witasek.com • www.witasek.com

LEGAL NOTICE: Publisher responsible for contents: witasek PflanzenSchutz GmbH. Great care has been exercised in providing information. We can accept no liability for misprints and other errors. Contents may be subject to change without notice. Our general terms of supply and payment apply. To view our GTCs, go to www.witasek.com



WitaTrap®



Complete Plum Fruit Moth Trap Set

Plum fruit moth (*Grapholita funebrana*)

Biological attractant trap (pheromone trap) for the management of pest infestation of your cultivars.

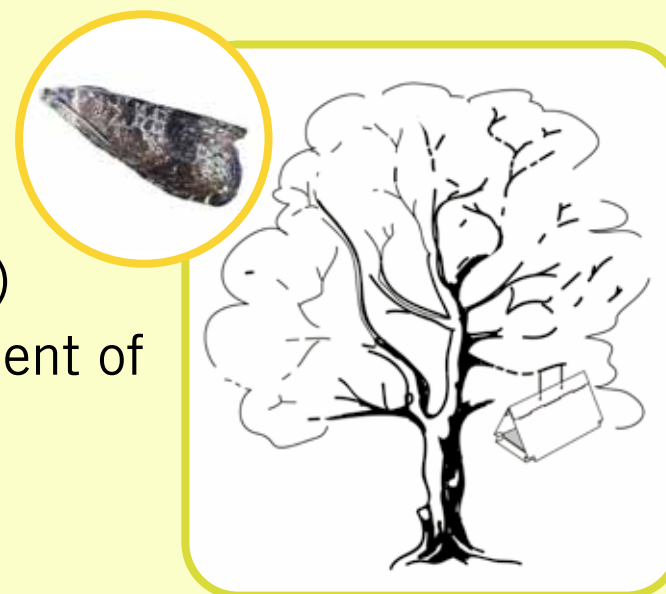

► See inside for more information

Plum fruit moth (*Grapholita funebrana*)

Pest: plum fruit moth
 Scientific name: *Grapholita funebrana*
 Infests: Plums, damsons and mirabelles



Main symptoms of infestation:

- Larvae bore into fruits
- There is frequently a drop of gum-like substance at the entrance to bore holes
- The fruit flesh around the stone is destroyed
- Fruits ripen prematurely and drop from trees

Biology:

Larvae overwinter in cocoons located under a sliver of tree bark or, less commonly, in the soil. The first adult moths emerge in May and lay single eggs on fruits. The hatched larvae bore into fruits, subsequently leaving these to pupate in the trunks of trees.

The adult moths of the second generation emerge in late July and deposit their eggs on the already ripening fruits. The resultant larvae again bore into fruits and can cause extensive losses to the fruit yield. They overwinter in cocoons.

Egg deposition: each female lays some 40 - 60 eggs

Development phase from egg to larva: approx. 10 - 14 days

Main flight periods of the first generation adults:

May and June (usually in the evening)

Main flight periods of the second generation adults:

July to August (usually in the evening)



Practical advice: The risk of reinfestation is reduced if fallen fruits are removed.

The use of pheromone traps is an excellent way of controlling levels of flying pest insects and beetles.

Purpose of pheromone traps:

- They are used to monitor levels of infestation and to determine whether adults are taking flight. Further suitable targeted measures (biological or standard plant protection methods) can then be initiated as necessary.
- Reduction of numbers of pest insects.

Use:

Assemble the trap and hang it using the suspension wire from a branch or post. (See other side for assembly instructions)

In order to avoid attracting the pest insects directly to the plum/damson tree to be protected, hang the trap from another tree (that is not a fruit tree) in the vicinity. If this is not possible, the trap can also be hung from a suitably high post driven into the ground.

Hang the trap at eye level between the main wind direction and the tree. Make sure the trap entrances are not blocked by twigs and leaves.

Each trap should be checked at regular intervals of 2 - 3 days. Each time a trap is checked, the insects sticking to the adhesive base should be removed using a suitable tool (e.g. twig or wooden scraper) to ensure that the full glue surface is revealed. If the base becomes very soiled, replace it or spray with a liquid glue, such as Soveurode special glue.

Replace the attractant capsule and the adhesive base if necessary roughly every 4 - 6 weeks.

*Traps should be put in place before the flight phase of the adults.

Storage:

Store the pheromones prior to use in the original packaging in a cold place (e.g. refrigerator or freezer compartment) at a maximum temperature of +4°C (no risk to foodstuffs).

Disposal:

Used traps can be disposed of with domestic waste.



Period of use*

Trap set

Art. No.	Product
343411	WitaTrap® Complete Plum Fruit Moth Trap Set (<i>Grapholita funebrana</i>)

Reconditioning

If adhesive bases collect too many insects and become badly soiled, these should be replaced or resprayed with a liquid glue, such as Soveurode special glue. Additional adhesive bases can be separately ordered.

Art. No.	Product
391111	Adhesive base for the WitaTrap® Delta Super - pack of two bases
381211	Soveurode special glue (sprayable glue)

Orders can be placed by phone, fax or email.

Tel.: +43 (0)4276/ 3230 | Fax: +43 (0) 4276/ 2088-399 | Email: office@witasek.com